

- NOTE:
1. TRACTION TREAD REAR TIRES.
 2. 12 GA S/S BODY.
 3. HOSE BED CAPACITY = 56 TO 70 CU. FT.
 4. TANK TO PUMP W/ 1/4" AIR OPERATED VALVE
 5. AKRIN 721 BOOSTER REEL NOZZLE.
 6. TANK FILL LINE 2 1/2" FROM PUMP.
 7. FOAM PRO 2002 FOAM SYSTEM.
 8. FIBERGLD COMPT. ROPE LIGHTING.
 9. HANNAY 220V ELEC. REV'D CDREELS W/200' OF 10/4 EACH.
 10. (2) FIRE RESEARCH 750 WATT TRIPD QUARTZ LIGHTS
 11. (2) FIRE RESEARCH 1500 WATT TELESCOPING QUARTZ LIGHTS
 12. TWO TONE CAB EXTERIOR.
 13. 8" SCHITLITE STRIPE.
 14. (4) STREAMLITE HANDLIGHTS
 15. ADJ. SHELVES TO BE LOCATED.
 16. STAINLESS ROLL-OUT TRAY IN REAR COMPT.
 17. AMPS 10,000 WATT HYD. PTD GENERATOR
 18. (2) GENERATOR RUNNING LIGHTS
 19. (2) HANNAY 220V ELEC. REV'D CDREELS W/200' OF 10/4 EACH.
 20. (2) FIRE RESEARCH 750 WATT TRIPD QUARTZ LIGHTS
 21. (2) FIRE RESEARCH 1500 WATT TELESCOPING QUARTZ LIGHTS
 22. TWO TONE CAB EXTERIOR.
 23. 8" SCHITLITE STRIPE.
 24. (4) STREAMLITE HANDLIGHTS

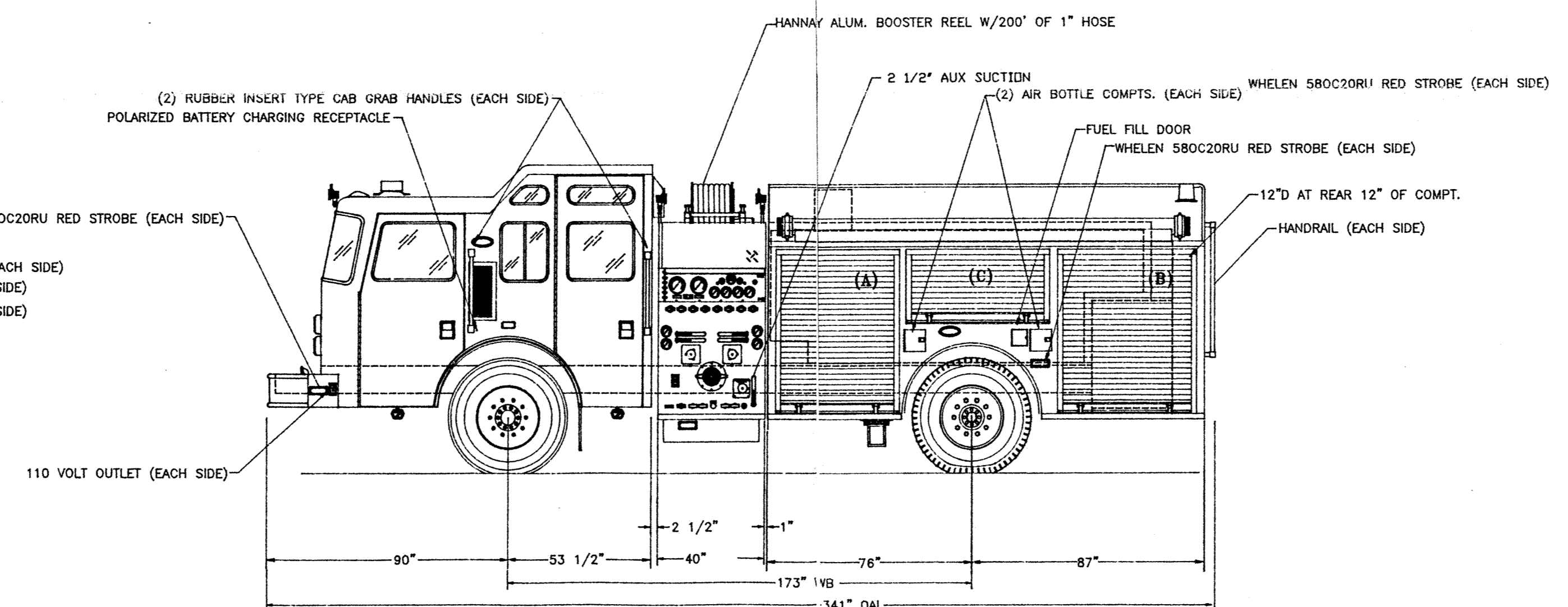
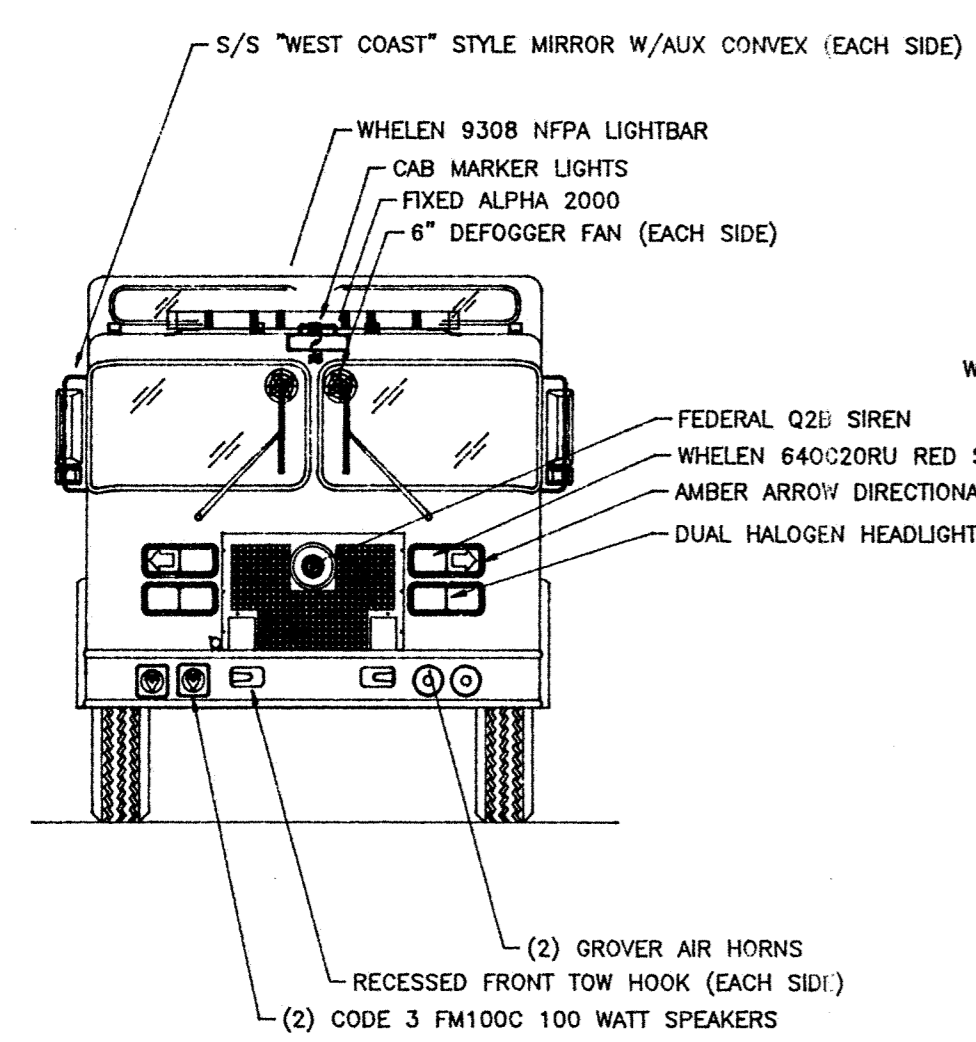
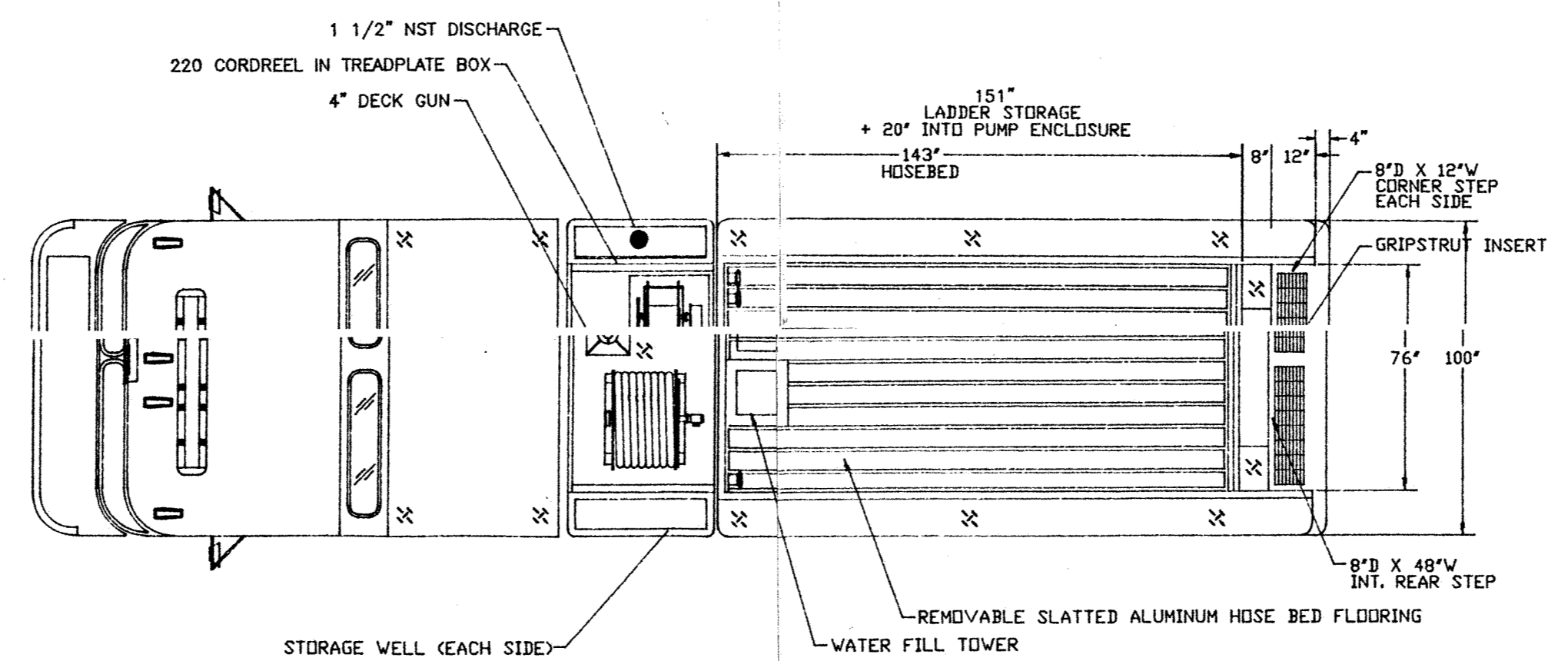
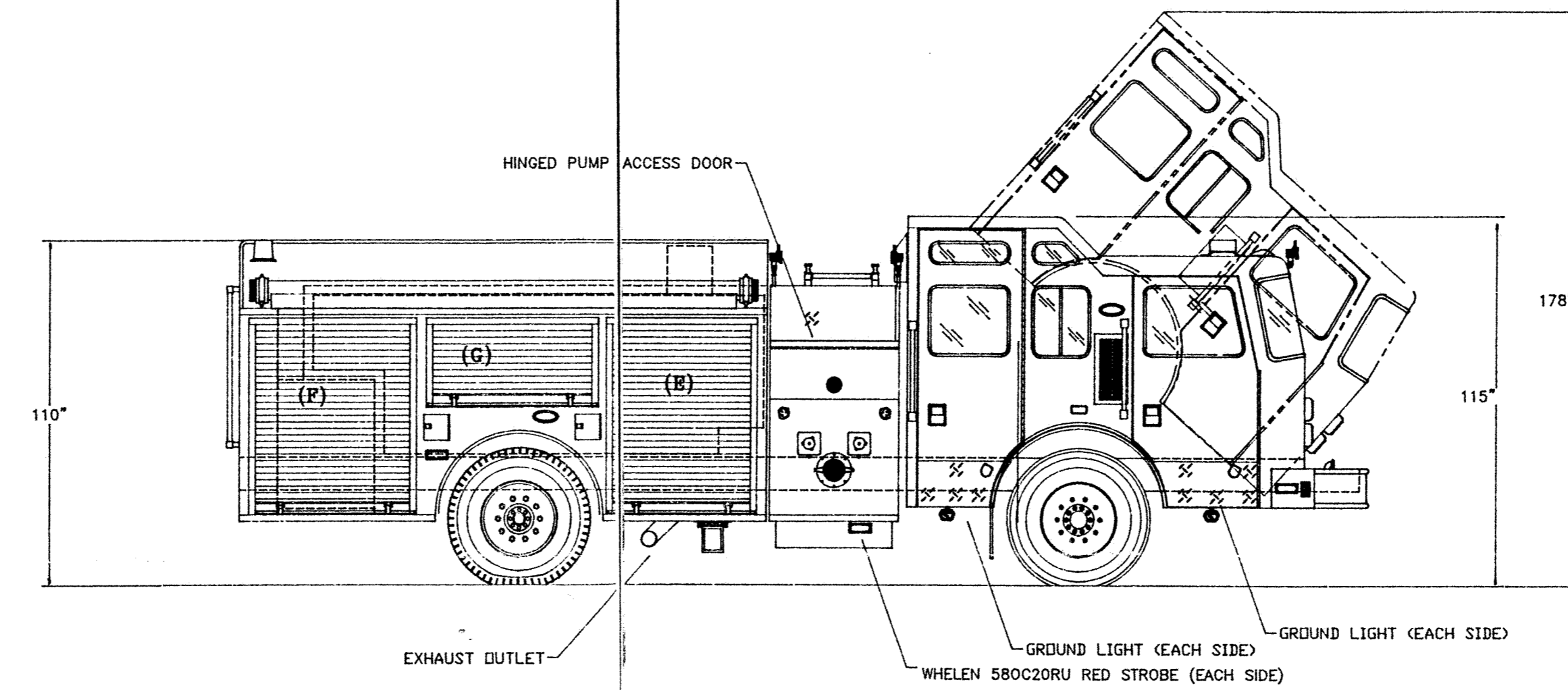

SPECIFICATIONS

CHASSIS: KME RENEGADE CONTOUR TILT MFD W/12 RR
ENGINE: DETROIT SERIES 60 370 HP
TRANSMISSION: ALLISON HD-4060P 5-SPD AUTO
FRONT AXLE: MERITOR FL-941 18,000#
REAR AXLE: MERITOR RS-24-160 24,000#
PUMP: HALE QMAX150 1500 GPM SINGLE STAGE
WATER TANK: 1000 GALLON POLY II W/40 FOAM

COMPARTMENT SIZE

- (A): 62"H X 49 3/4"W X 24"D
- (B): 62"H X 52 3/4"W X 24"D
- (C): 29 1/2"H X 56"W X 24"D
- (D): 40"H X 46"W X 20"D
- (E): 62"H X 49 3/4"W X 24"/12"D
- (F): 62"H X 52 3/4"W X 24"/12"D
- (G): 29 1/2"H X 56"W X 12"D

DOOR OPENING

- (A): 61"H LESS LIFT BAR HEIGHT X 46"W
- (B): 61"H LESS LIFT BAR HEIGHT X 52"W
- (C): 27 1/2"H LESS LIFT BAR HEIGHT X 53"W
- (D): 39"H LESS LIFT BAR HEIGHT X 45 1/2"W
- (E): 61"H LESS LIFT BAR HEIGHT X 46"W
- (F): 61"H LESS LIFT BAR HEIGHT X 52"W
- (G): 27 1/2"H LESS LIFT BAR HEIGHT X 53"W

DISCHARGES

- (2) 2 1/2" LEFT SIDE
- (1) 2 1/2" & (1) 4" RIGHT SIDE
- (1) 4" DECK GUN
- (1) 2" FRONT BUMPER
- (1) 2" RIGHT FRONT HOSEBED
- (1) 1" BOOSTER REEL
- (2) 2" LEFT FRONT HOSEBED

PLEASE REVIEW AND RETURN A SIGNED COPY.

NAME: _____

TITLE: _____

CUSTOMER PAINT CODES:

LOWER CAB AND BODY: _____

CAB TWO TONE: _____

THIS DRAWING IS A GENERAL CONFIGURATION AND MAY NOT NECESSARILY REFLECT ALL CONTRACTUAL REQUIREMENTS.

SYM	DATE	REVISION DESCRIPTION	APP'D
D	4-18-01	REVISED AFTER MEETING	
C	12-13-00	REVISED TO GSD#	
B	7-18-00	REVISED	
A		PROPOSAL	A.Y.

SALES ENGINEER : JIM HAUSER

KOVATCH MOBILE EQUIPMENT
ONE INDUSTRIAL COMPLEX
NESQUEHONING, PA 18240

TOLERANCE UNLESS OTHERWISE SPECIFIED
DECIMALS FRACTIONS: ± 1/8"
ONE PLACE: ± .060 THREE PLACE: ± .010 REMOVE ALL BURRS
TWO PLACE: ± .030 ANGLES: ± 2° AND SHARP EDGES

DATE SCALE DRAWN BY APPROVED BY
6-14-00 NONE JJM

KME CUSTOM PUMPER

ELVERSON PA

GSO#4843

CAD DO NOT CHANGE MANUALLY